

Neurons vs. Other Cells

- ❖ Specialized extensions: dendrites and axons
- ❖ Neurons communicate with each other through an electrochemical process.

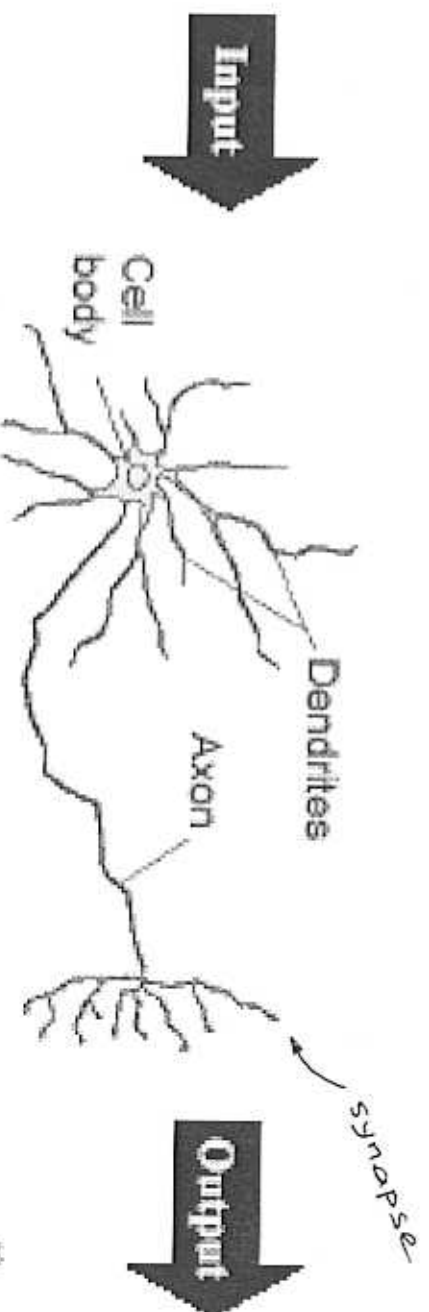

Axonal Signals

- ❖ An electrical signal
- ❖ 20 m/s to 100 m/s

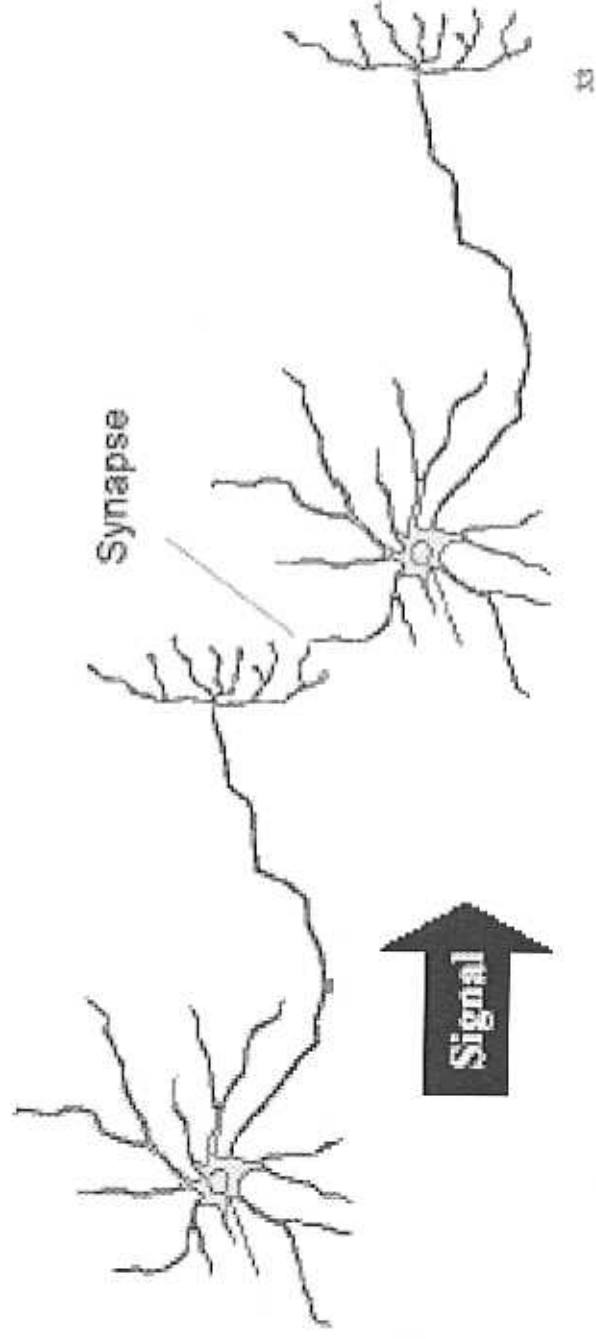

A Synapse

❖ From an electron microscope



Synapse

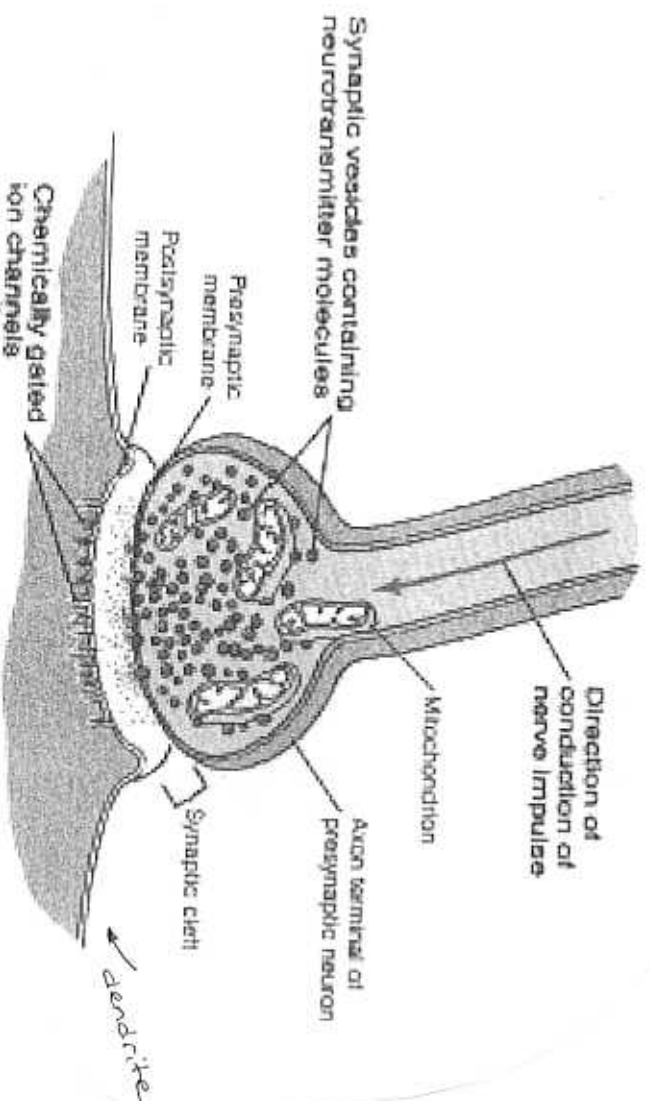

Different Neurons

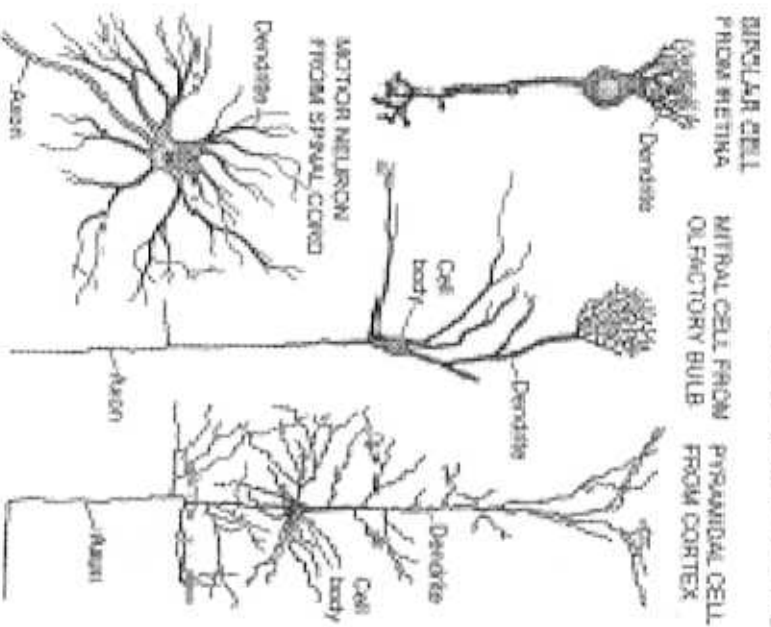

- ❖ Neurons (nerve cells) come in many different shapes and sizes
- ❖ Some of the smallest neurons have cell bodies that are only 4 microns wide, while some of the biggest neurons have cell bodies that are 100 microns wide.

A Neural Network

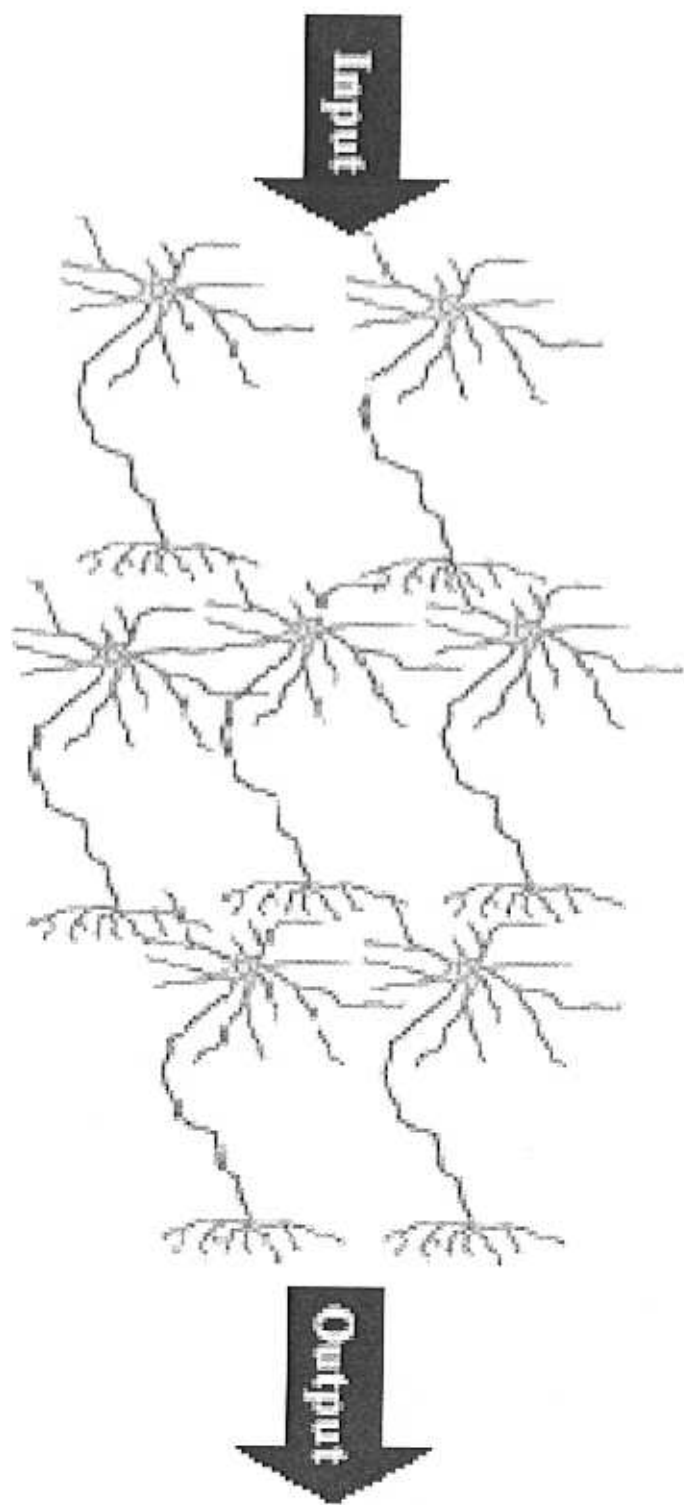

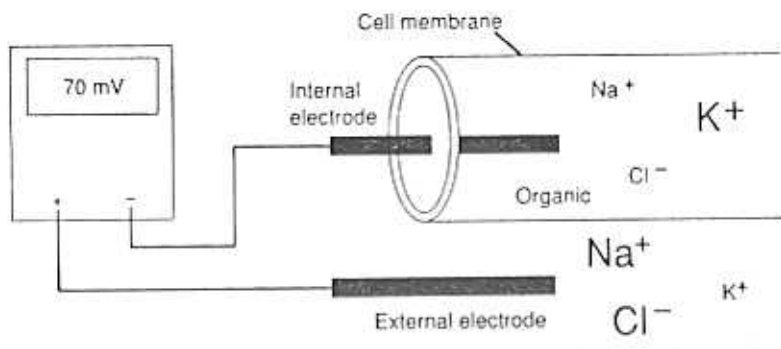

Figure 1.5 This figure illustrates the resting potential developed across the cell membrane of a neuron. The relative sizes of the labels for the ionic species indicate roughly the relative concentration of each species in the regions internal and external to the cell.

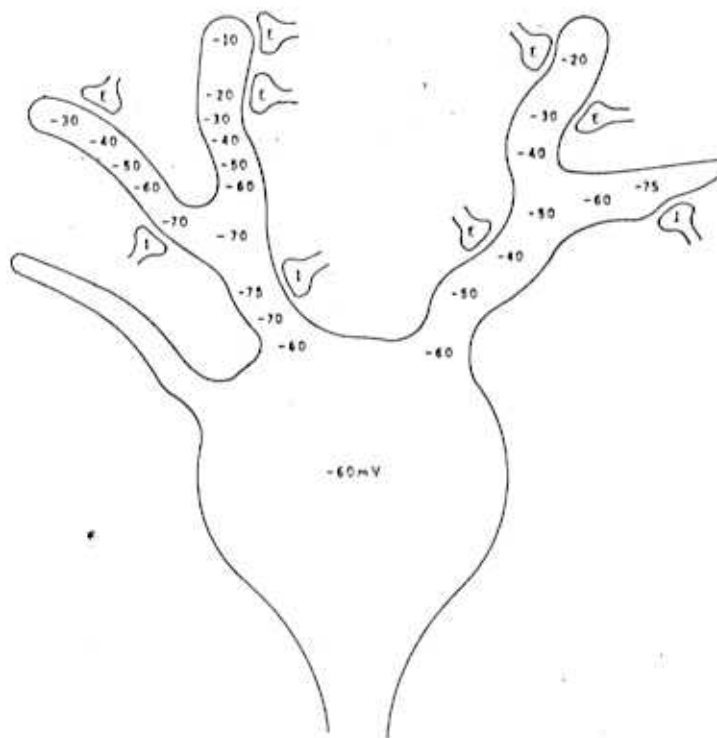
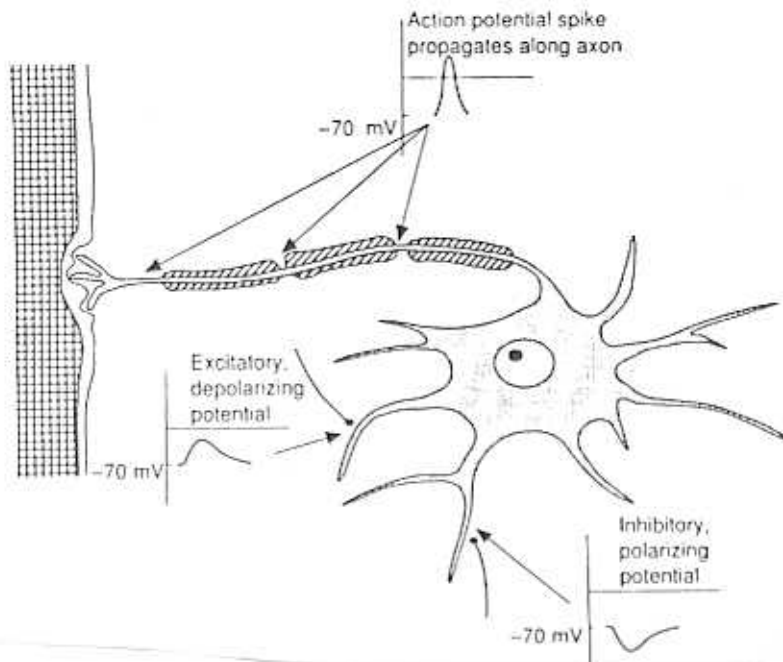

Figure 2.16: Stimulation of a neuron by synaptic inputs of different types located at many points on dendrites produces a variety of electrical effects depending on the location and time sequencing of the various inputs.



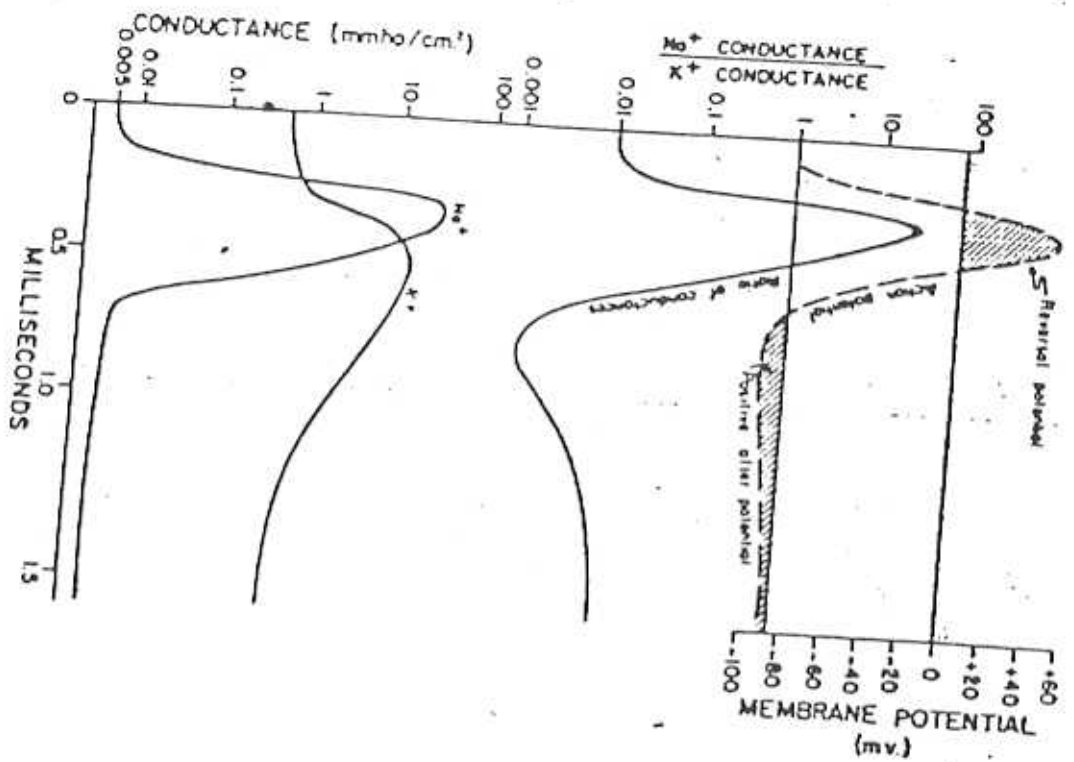
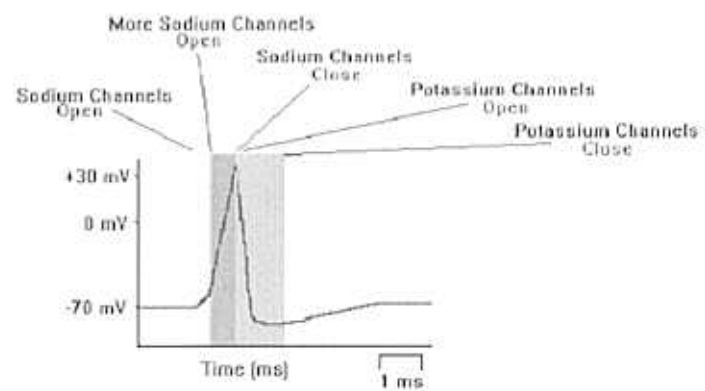

Figure 2.17: Changes in sodium (Na^+) and potassium (K^+) permeability (i.e., conductance) versus time during the course of the action potential. Once the axon membrane potential rises above about -50 millivolts, Na^+ conductance spontaneously increases several thousand percent. When this happens, Na^+ ions rush in, causing the potential inside the axon to rise to about $+50$ millivolts. Then within about 0.5 millisecond, the sodium conductance drops almost as abruptly as it rose. Meanwhile, potassium conductance begins to rise, causing K^+ ions to rush out and driving the axon potential even more negative than before. Gradually, over about 1.5 milliseconds, the conductances and voltage return to normal.

Metabolism when neuron becomes active



BİYOLOJİK SİNİR HÜCRE MODELLERİ

Hodgkin-Huxley Modeli

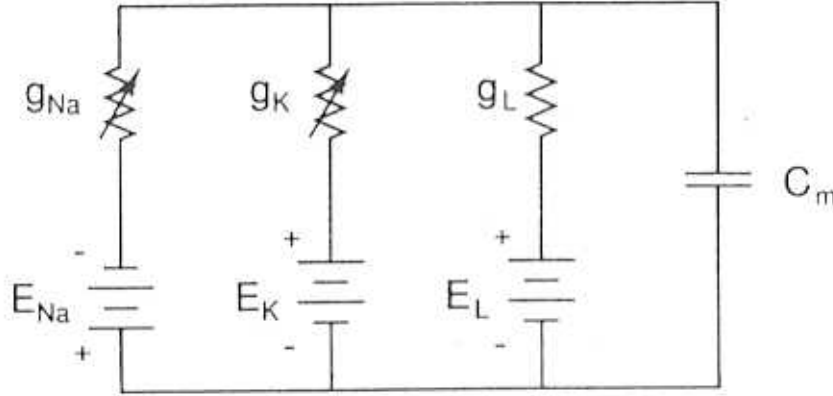

Hodgkin-Huxley'in hücre zarı için önerdikleri analog devre

V: zar gerilimi, **C**: zar kapasitesi, **g**: iletkenlik, **I**: giriş akımı.

$$I = C \frac{dV}{dt} + g_{Na}(V - E_{Na}) + g_K(V - E_K) + g_L(V - E_L)$$

$$i_{Na} = g_{Na}(V - E_{Na}), i_K = g_K(V - E_K)$$

DeneySEL çalışmalarında topladıkları veriler sonucunda aşağıdaki bağıntıları elde etmişlerdir.

$$g_K = g_{K(max)}n^4, n \in [0, 1]; g_{Na} = g_{Na(max)}m^3h, m \in [0, 1].$$

$$\frac{dn}{dt} = \alpha_n(1 - n) - \beta_n n.$$

$$\frac{dm}{dt} = \alpha_m(1 - m) - \beta_m m.$$

$$\frac{dh}{dt} = \alpha_h(1 - h) - \beta_h h.$$

Burada, g_L sabittir ve $\alpha_n, \alpha_m, \alpha_h, \beta_n, \beta_m, \beta_h$ gerilime bağılı orantı katsayılarıdır.

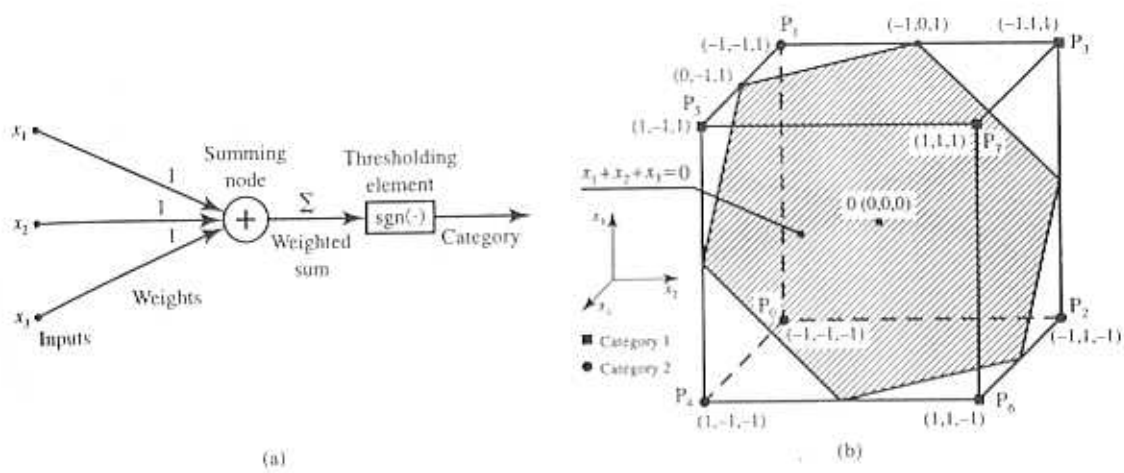

Figure 1.1 Partitioning of the set of cube vertices: (a) single-unit diagram and (b) implemented partitioning.

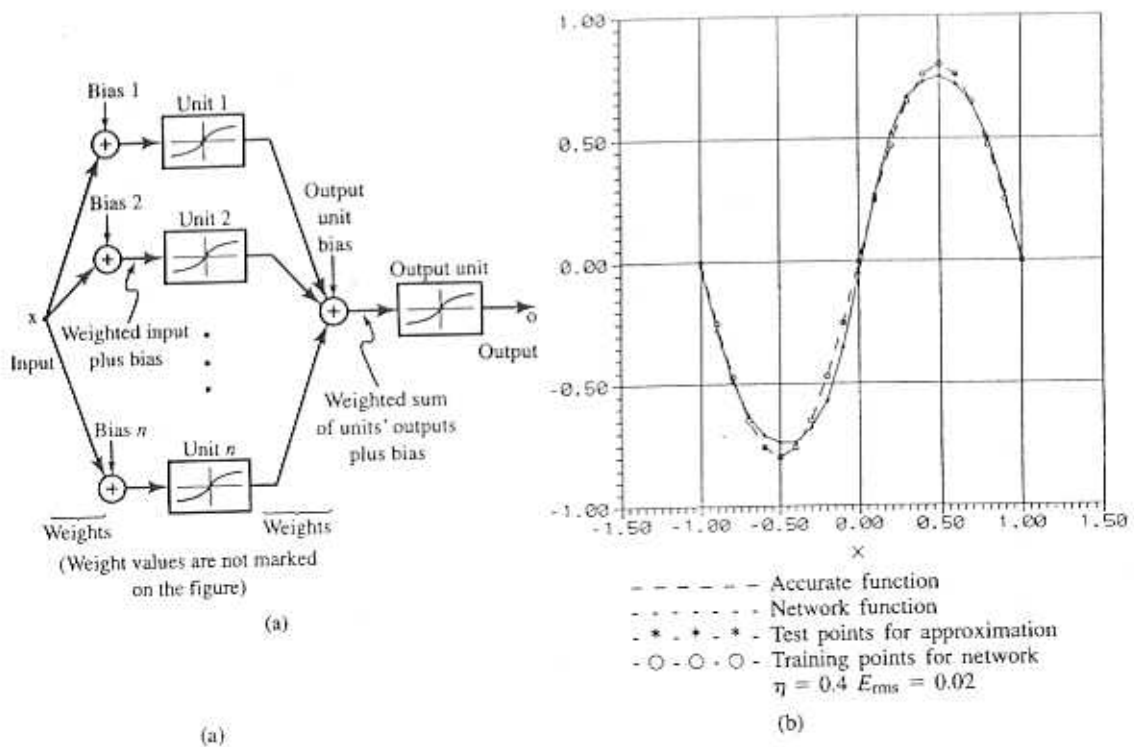
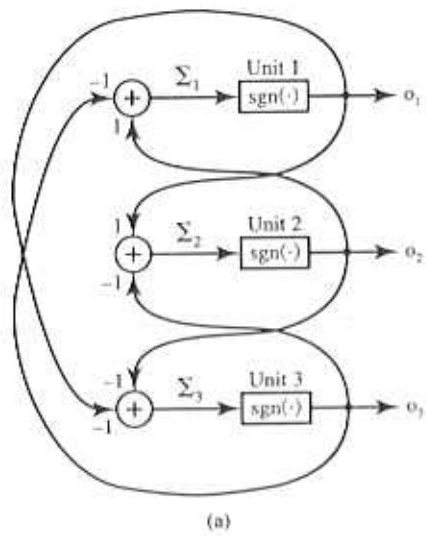

Figure 1.3 Neural network with continuous units as function approximator: (a) block diagram and (b) example approximation of Equation (1.2).



Case	Unit Number	Present Output O	Σ	$\text{sgn } \Sigma$	Next Output O
1	1	1	0	x	1
	2	1	0	x	1
	3	1	-2	-1	(-1)
2	1	1	2	1	1
	3	-1	-2	-1	-1
3	1	-1	2	1	(1)
	3	-1	0	x	-1
4	1	1	0	x	1
	2	-1	2	1	1
	3	-1	0	x	-1

x stands for $\text{sgn}(0)$.
Encircled are updated outputs.

(b)

Figure 1.5 Simple neural network memory: (a) network diagram and (b) listing of updates.

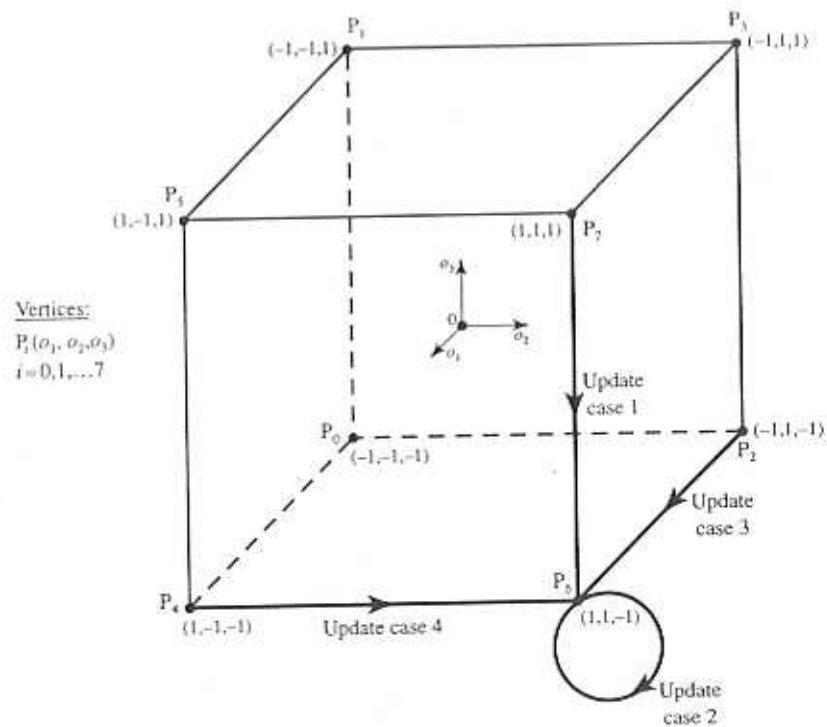

Figure 1.6 Graphical interpretation of the memory network from Figure 1.5.